

NOBLELIFT

www.noblelift.com

SWB-130/130S/130D

Walkie Electric Stacker



NEW *Noblelift Products*
ARRIVAL

SWB-130/130S/130D

Noblelift Walkie Electric Stacker

With a full free lifting mast, this stacker offers an ideal solution for material handling in confined spaces like supermarkets and internal workshops. Standard with a lithium battery, it ensures quick replacement and charging flexibility.

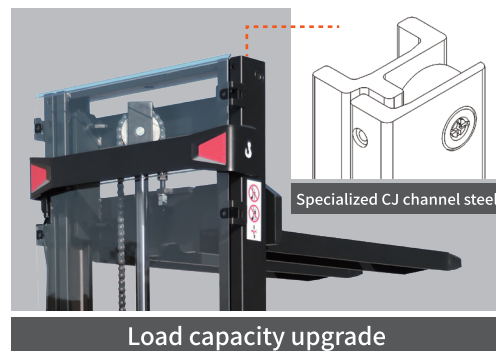
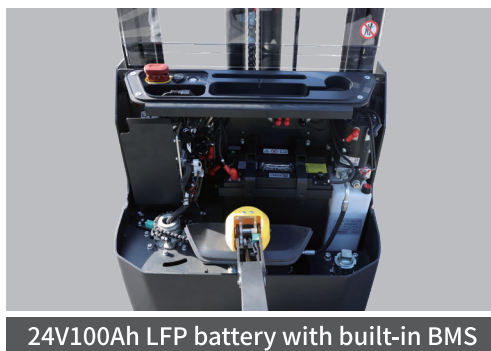

- Load capacity is upgraded to 1.3t, meeting the needs of customers better.
- The full free lifting mast is an ideal choice for working in limited height spaces.
- Soft start enables more stable and controllable lifting operations.
- Stability and performance of the truck is enhanced greatly via specialized CJ channel steel.
- Vertical drive function enables easy steering in narrow spaces such as lorries and elevators safely.

SWB-130/130S/130D

- External programming port, diagnosing faults without removing the cover. Convenient and fast maintenance.
- Patented chain turning structure with high strength.
- Standard speed reduction at turns ensures stability and safety during large angle turns.
- Makes it convenient to adjust the pressure on top of supporting wheels without lifting up the machine.



Smart Lithium Battery



SWB-130S

Charger
24V/25A



4Hr



24V
100Ah



All Li-ion batteries are equipped with built-in Battery Management System(BMS), which provides mandatory control of all important parameters of the battery during charging and operation. With this control, the safety of Li-ion battery during the whole life-cycle is guaranteed. The Li-ion batteries are certified according to international safety transportation (by sea and by air) and operation standards. The BMS communicates with control system of the truck via CAN-BUS, uploading key status data and can make its diagnosis and repair with special software.

SWB-130/130S/130D

The machine can ensure high efficiency even in multiple shifts. Lithium batteries have functions such as fast charging, maintenance free, environmentally friendly, and intelligent display, while also easy to maintain, cost-effective, and improving work efficiency greatly.

Ergonomic & smart tiller

The tiller of the truck with ergonomic design has comfortable soft grips for comfort daily operation. All buttons are big and can be easily reached by operators even in case of working in gloves.

Integrated PIN code panel with LCD display for smart control and operation.

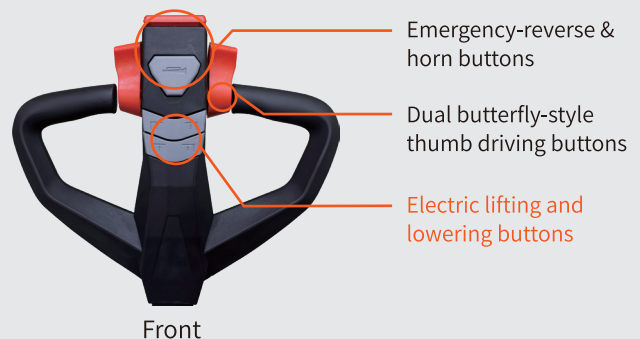

Power display
Working hour
Fault code display

Back

Front

Mast table SWB-130

Designation	Lowered mast height h1 (mm)	Free lift height h2 (mm)	Lift height h3 (mm)	Extended mast height h4 (mm)	Lift + fork height h3 + h13(mm)
Two-stage mast	1780	1300	2510	2990	2600
	1930	1450	2810	3290	2900
	2080	1600	3110	3590	3200
	2280	1800	3510	3990	3600
Three stage mast	1982	1440	4210	4752	4300

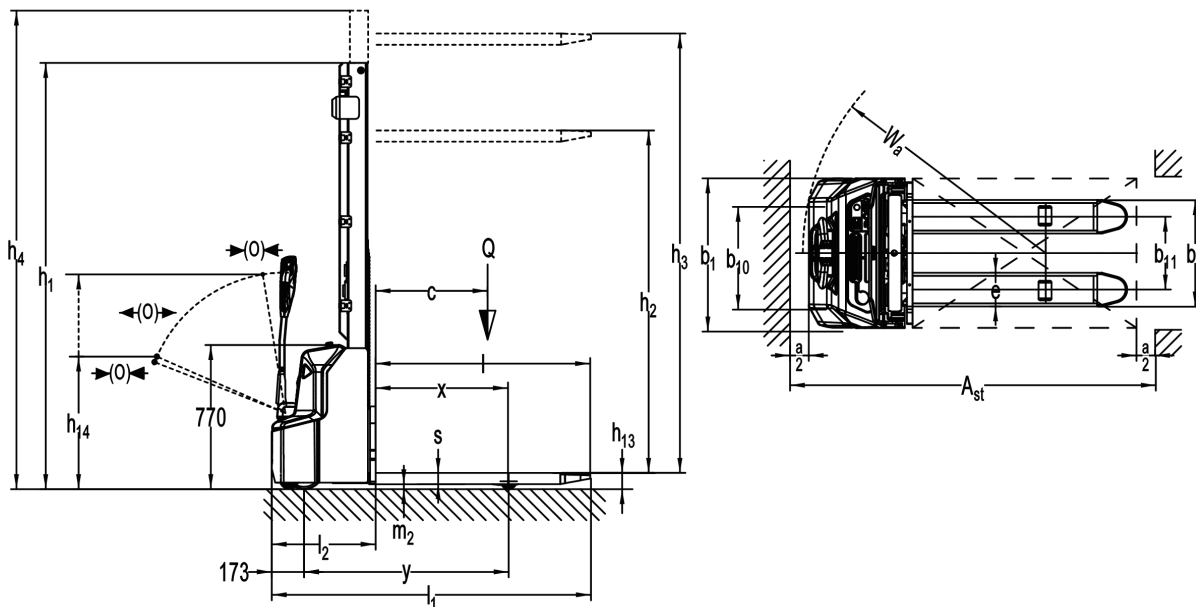

Mast table SWB-130S

Designation	Lowered mast height h1 (mm)	Free lift height h2 (mm)	Lift height h3 (mm)	Extended mast height h4 (mm)	Lift + fork height h3 + h13(mm)
Two-stage mast	1790	1300	2510	3055	2560
	1940	1450	2810	3355	2860
	2090	1600	3110	3655	3160
	2290	1800	3510	4055	3560

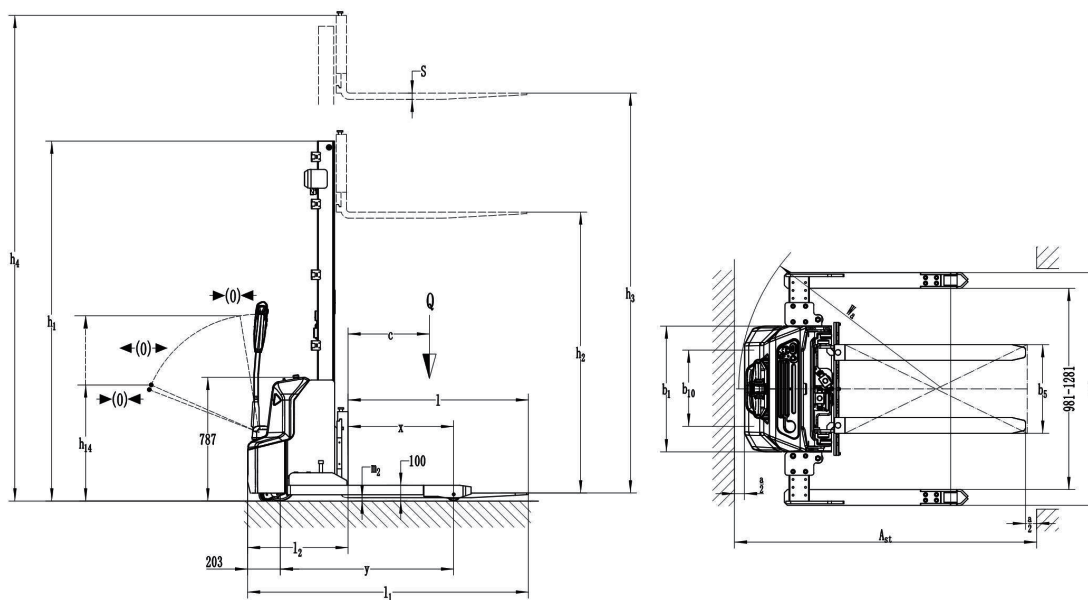

Mast table SWB-130D

Designation	Lowered mast height h1 (mm)	Free lift height h2 (mm)	Lift height h3 (mm)	Extended mast height h4 (mm)	Lift + fork height h3 + h13(mm)
Two-stage mast	1820	1300	2510	3030	2600
	1970	1450	2810	3330	2900
	2120	1600	3110	3630	3200
	2320	1800	3510	4030	3600
Three stage mast	1986	1410	4120	4681	4200
	2026	1440	4210	4820	4300

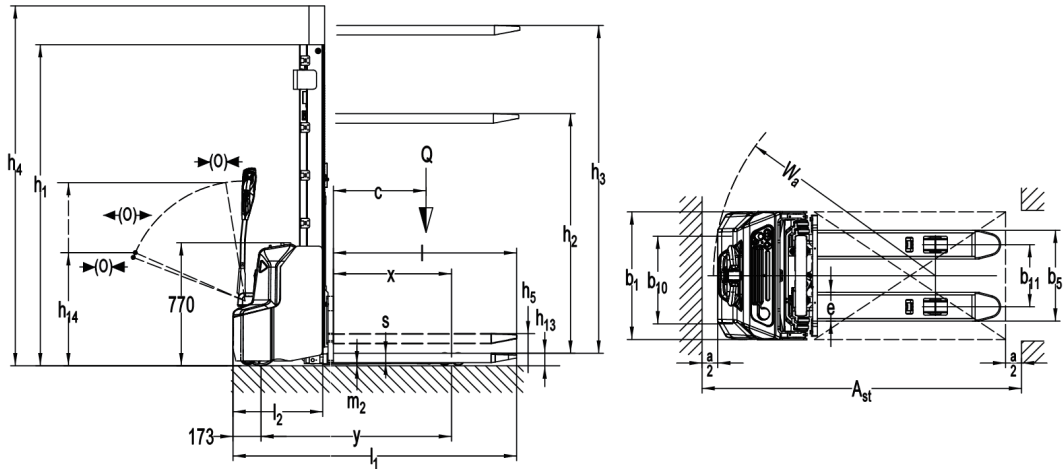

Three stage mast

Type sheet for industrial truck acc. to VDI 2198

No.20250904

Distinguishing mark

1.2	Manufacturer`s type designation		SWB-130	SWB-130
			3600FFL	4300FFL
1.3	Power (battery ,diesel, petrol, gas, manual)		Battery	Battery
1.4	Operator type		Pedestrian	Pedestrian
1.5	Load Capacity / rated load	Q (t)	1.3	1.3
1.6	Load centre distance	c (mm)	600	600
1.8	Load distance ,centre of drive axle to fork	x (mm)	710	693
1.9	Wheelbase	y (mm)	1097	1097

Weight

2.1	Service weight	kg	715	670	772	732
2.2	Axle loading, laden front/rear	kg	580/1435	560/1410	610/1462	585/1447
2.3	Axle loading, unladen front/rear	kg	500/215	480/190	548/224	520/212

Tires, chassis

3.1	Tires		Polyurethane	Polyurethane
3.2	Tire size, front	Øxw (mm)	Ø210×75	Ø210 x 75
3.3	Tire size, rear	Øxw (mm)	Ø84x93	Ø84x93
3.4	Additional wheels(dimensions)	Øxw (mm)	Ø 100x50	Ø 100x50
3.5	Wheels, number front/rear(x=driven wheels)		1x +1/2	1x + 2/2
3.6	Track, front	b10 (mm)	550	550
3.7	Track, rear	b11 (mm)	400/515	400

Dimensions

4.2	Lowered mast height	h1 (mm)	2280	1982
4.3	Free Lift height	h2 (mm)	1800	1440
4.4	Lift height	h3 (mm)	3510	4210
4.5	Extended mast height	h4 (mm)	3990	4752
4.9	Height of tiller in drive position min./ max.	h14 (mm)	710/1150	710/1150
4.15	Height, lowered	h13 (mm)	90	90
4.19	Overall length	l1 (mm)	1710	1724
4.20	Length to face of forks	l2 (mm)	560	574
4.21	Overall width	b1 (mm)	800	800
4.22	Fork dimensions	s/e/l (mm)	60/180/1150	60 / 180 / 1150
4.25	Width across forks	b5 (mm)	570/685	570
4.32	Ground clearance, centre of wheelbase	m2 (mm)	24	26
4.33	Aisle width for pallets 1000X1200 crossways	Ast (mm)	2167	2167
4.34	Aisle width for pallets 800X1200 lengthways	Ast (mm)	2133	2133
4.35	Turning radius	Wa (mm)	1300	1300

Performance data

5.1	Travel speed, laden/ unladen	km/h	4.2/4.5	4.2/4.5
5.2	Lift speed, laden/ unladen	m/s	0.10/0.14	0.10/0.14
5.3	Lowering speed, laden/ unladen	m/s	0.13/ 0.11	0.13/ 0.11
5.8	Max. gradeability, laden/ unladen	%	4 / 10	4 / 10
5.10	Service brake		electromagnetic	electromagnetic

Electric- engine

6.1	Drive motor rating S2 60min	kW	0.65	0.65
6.2	Lift motor rating at S3 7.5%	kW	2.2	2.2
6.3	Battery acc. to DIN 43531/35/36 A, B, C, no		no	no
6.4	Battery voltage, nominal capacity K2	V/Ah	2x12/106(Pb-acid) 24/100(Li)	2x12/106(Pb-acid) 24/100(Li)
6.5	Battery weight +/-5%	kg	2x34 26	2x34 27
6.6	Energy consumption acc: to VDI cycle	KWh/h	0.68	0.70

Additional data

8.1	Type of drive control		DC	DC
8.4	Sound level at driver`s ear acc. to EN 12053	dB (A)	<70	<70

Distinguishing mark

1.2	Manufacturer`s type designation		SWB-130S
			3600FFL
1.3	Power (battery ,diesel, petrol, gas, manual)		Battery
1.4	Operator type		Pedestrian
1.5	Load Capacity / rated load	Q (t)	1.27
1.6	Load centre distance	c (mm)	600
1.8	Load distance ,centre of drive axle to fork	x (mm)	674
1.9	Wheelbase	y (mm)	1111

Weight

2.1	Service weight	kg	880	835
2.2	Axle loading, laden front/rear	kg	655 / 1495	635 / 1470
2.3	Axle loading, unladen front/rear	kg	615 / 265	595 / 240

Tires, chassis

3.1	Tires		Polyurethane
3.2	Tire size, front	Øxw (mm)	Ø210 x 75
3.3	Tire size, rear	Øxw (mm)	Ø84x93
3.4	Additional wheels(dimensions)	Øxw (mm)	Ø 100x40
3.5	Wheels, number front/rear(x=driven wheels)		1x + 2/2
3.6	Track, front	b10 (mm)	520
3.7	Track, rear	b11 (mm)	/

Dimensions

4.2	Lowered mast height	h1 (mm)	2290
4.3	Free Lift height	h2 (mm)	1800
4.4	Lift height	h3 (mm)	3510
4.5	Extended mast height	h4 (mm)	4055
4.9	Height of tiller in drive position min./ max.	h14 (mm)	710/1150
4.15	Height, lowered	h13 (mm)	50
4.19	Overall length	l1 (mm)	1790
4.20	Length to face of forks	l2 (mm)	640
4.21	Overall width	b1 (mm)	800 / (1181 / 1231 / 1281 / 1381 / 1481)
4.22	Fork dimensions	s/e/l (mm)	40/100/1150
4.25	Width across forks	b5 (mm)	252-800
4.32	Ground clearance, centre of wheelbase	m2 (mm)	40
4.33	Aisle width for pallets 1000X1200 crossways	Ast (mm)	2228
4.34	Aisle width for pallets 800X1200 lengthways	Ast (mm)	2206
4.35	Turning radius	Wa (mm)	1345

Performance data

5.1	Travel speed, laden/ unladen	km/h	4.2/4.5
5.2	Lift speed, laden/ unladen	m/s	0.10/0.14
5.3	Lowering speed, laden/ unladen	m/s	0.13/ 0.11
5.8	Max. gradeability, laden/ unladen	%	4 / 10
5.10	Service brake		electromagnetic

Electric- engine

6.1	Drive motor rating S2 60min	kW	0.65
6.2	Lift motor rating at S3 7.5%	kW	2.2
6.3	Battery acc. to DIN 43531/35/36 A, B, C, no		no
6.4	Battery voltage, nominal capacity K2	V/Ah	2x12/106(Pb-acid) 24/100(Li)
6.5	Battery weight +/-5%	kg	2 x 34 26
6.6	Energy consumption acc: to VDI cycle	KWh/h	0.70

Additional data

8.1	Type of drive control		DC
8.4	Sound level at driver`s ear acc. to EN 12053	dB (A)	<70

Type sheet for industrial truck acc. to VDI 2198

No.20250904

Distinguishing mark

1.2	Manufacturer`s type designation		SWB-130D 3600FFL	SWB-130D 4300FFL
1.3	Power (battery ,diesel, petrol, gas, manual)		Battery	Battery
1.4	Operator type		Pedestrian	Pedestrian
1.5	Load Capacity / rated load		1.3 ¹⁾	1.3 ¹⁾
	Load Capacity / rated load (mast lift)	Q (t)	1.3	1.3
	Load Capacity / rated load (support arm lift)		1.3	1.3
1.6	Load centre distance	c (mm)	600	600
1.8	Load distance ,centre of drive axle to fork	x (mm)	758 / 675 ²⁾	745/650
1.9	Wheelbase	y (mm)	1197/ 1115 ²⁾	1192/1109

Weight

2.1	Service weight	kg	790	745	849	807
2.2	Axle loading, laden front/rear	kg	695/1395	675/1370	723/1426	701/1406
2.3	Axle loading, unladen front/rear	kg	540/250	520/225	584/265	562/245

Tires, chassis

3.1	Tires		Polyurethane	Polyurethane
3.2	Tire size, front	Øxw (mm)	Ø210×75	Ø210×75
3.3	Tire size, rear	Øxw (mm)	Ø84x93	Ø84x93
3.4	Additional wheels(dimensions)	Øxw (mm)	Ø 100x50	Ø 100x50
3.5	Wheels, number front/rear(x=driven wheels)		1x +1/4	1x +1/4
3.6	Track, front	b10 (mm)	550	550
3.7	Track, rear	b11 (mm)	390/505	390

Dimensions

4.2	Lowered mast height	h1 (mm)	2320	2026
4.3	Free Lift height	h2 (mm)	1800	1440
4.4	Lift height	h3 (mm)	3510	4210
4.5	Extended mast height	h4 (mm)	4030	4820
4.6	Initial lift	h5 (mm)	120	120
4.9	Height of tiller in drive position min./ max.	h14 (mm)	710/1150	710/1150
4.15	Height, lowered	h13 (mm)	90	90
4.19	Overall length	l1 (mm)	1762	1776
4.20	Length to face of forks	l2 (mm)	612	626
4.21	Overall width	b1 (mm)	800	806
4.22	Fork dimensions	s/e/l (mm)	60/180/1150	60/180/1150
4.25	Width across forks	b5 (mm)	570/685	570
4.32	Ground clearance, centre of wheelbase	m2 (mm)	24	25
4.33	Aisle width for pallets 1000X1200 crossways	Ast (mm)	2247 / 2203 ²⁾	2247 / 2203 ²⁾
4.34	Aisle width for pallets 800X1200 lengthways	Ast (mm)	2197 / 2181 ²⁾	2197 / 2181 ²⁾
4.35	Turning radius	Wa (mm)	1400 / 1320 ²⁾	1400 / 1320 ²⁾

Performance data

5.1	Travel speed, laden/ unladen	km/h	4.2/4.5	4.2/4.5
5.2	Lift speed, laden/ unladen	m/s	0.10/0.14	0.10/0.14
5.3	Lowering speed, laden/ unladen	m/s	0.13/ 0.11	0.13/ 0.11
5.8	Max. gradeability, laden/ unladen	%	4 / 10	4 / 10
5.10	Service brake		electromagnetic	electromagnetic

Electric- engine

6.1	Drive motor rating S2 60min	kW	0.65	0.65
6.2	Lift motor rating at S3 7.5%	kW	2.2	2.2
6.3	Battery acc. to DIN 43531/35/36 A, B, C, no		no	no
6.4	Battery voltage, nominal capacity K2	V/Ah	2x12/106(Pb-acid) 24/100(Li)	2x12/106(Pb-acid) 24/100(Li)
6.5	Battery weight +/-5%	kg	2x34 26	2x34 26
6.6	Energy consumption acc: to VDI cycle	KWh/h	0.69	0.69

Additional data

8.1	Type of drive control		DC	DC
8.4	Sound level at driver`s ear acc. to EN 12053	dB (A)	<70	<70

1) when operate the fork and pallet at the same time: Load Capacity / rated load (mast lift) < Load Capacity / rated load (support arm lift).

2) Load section lowered / Load section raised.

Working Together For A Shared Future

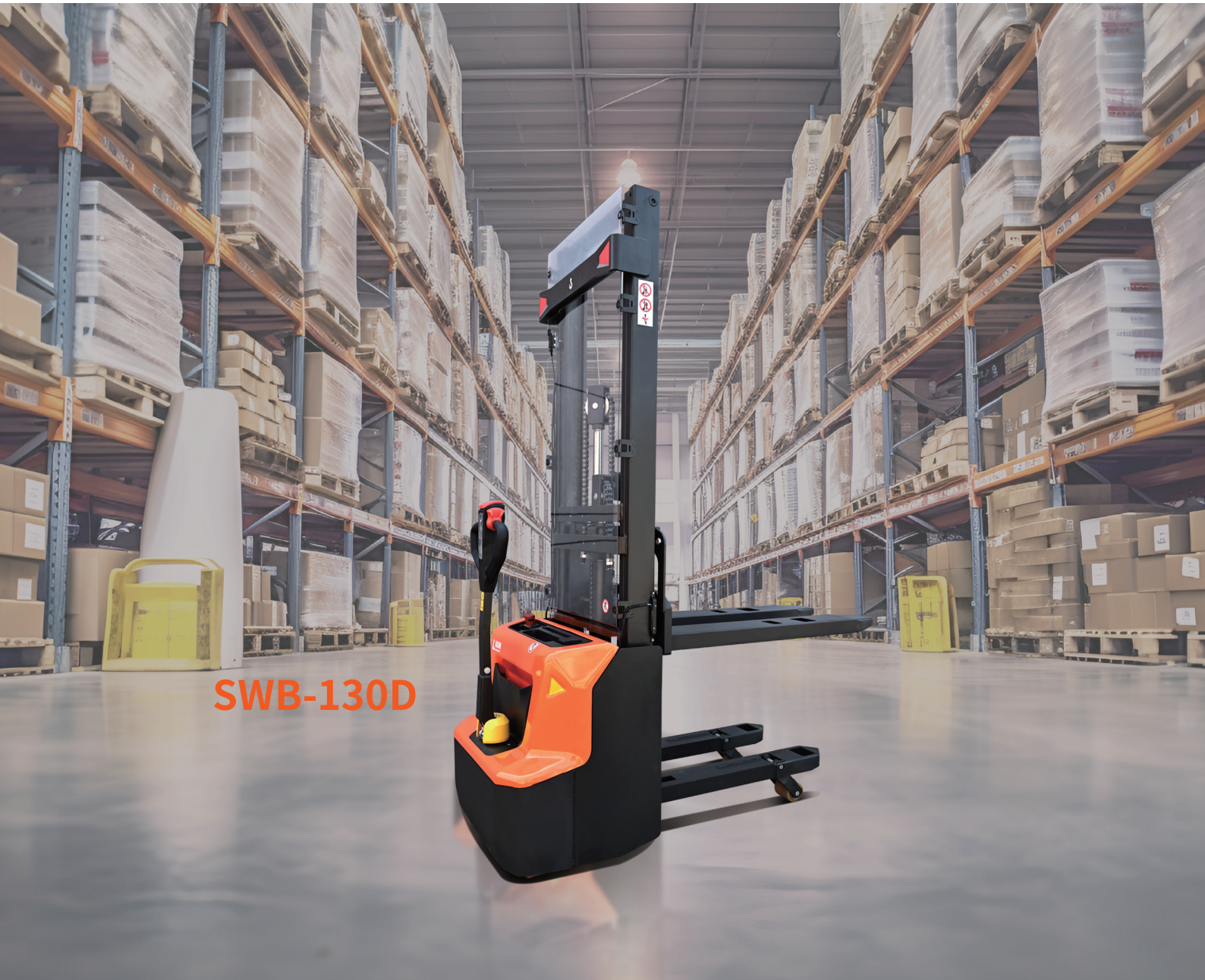

SWB-130D

NOBLELIFT CHINA

Add:528 Changzhou Road, Taihu Sub-district,
Changxing, Zhejiang 313100 China
Tel:86-572-6210817 6210311
Fax:86-572-6210777 6128612
Email: info@noblelift.com
Http: www.noblelift.com www.noblelift.cn



Official website



Our Wechat